

Technical Data - B30E

<p>ENGINE</p> <p>Manufacturer Mercedes Benz</p> <p>Model OM926LA</p> <p>Configuration Inline 6, turbocharged and intercooled.</p> <p>Gross Power 240 kW (322 hp) @ 2 200 rpm</p> <p>Net Power 232 kW (311 hp) @ 2 200 rpm</p> <p>Gross Torque 1 300 Nm (959 lbf) @ 1 200 -1 600 rpm</p> <p>Displacement 7,2 litres (439 cu.in)</p> <p>Auxiliary Brake Exhaust Valve Brake Engine Valve Brake</p> <p>Fuel Tank Capacity 379 litres (100 US gal)</p> <p>Certification OM926LA meets EU Stage II/EPA Tier 2 emissions regulations.</p>	<p>TRANSFER CASE</p> <p>Manufacturer Kessler</p> <p>Series W1400</p> <p>Layout Remote mounted</p> <p>Gear Layout Three in-line helical gears</p> <p>Output Differential Interaxle 33/67 proportional differential. Automatic inter-axle differential lock.</p>	<p>WHEELS</p> <p>Type Radial Earthmover</p> <p>Tyre 23.5 R 25</p>	<p>PNEUMATIC SYSTEM</p> <p>Air drier with heater and integral unloader valve, serving park brake and auxiliary functions.</p> <p>System Pressure 810 kPa (117 psi)</p>																					
<p>TRANSMISSION</p> <p>Manufacturer Allison</p> <p>Model 3500PR ORS</p> <p>Configuration Fully automatic planetary transmission with integral retarder.</p> <p>Layout Engine mounted</p> <p>Gear layout Constant meshing planetary gears, clutch operated</p> <p>Gears 6 Forward, 1 Reverse</p> <p>Clutch Type Hydraulically operated multi-disc</p> <p>Control Type Electronic</p> <p>Torque Control Hydrodynamic with lock-up in all gears.</p>	<p>AXLES</p> <p>Manufacturer Bell</p> <p>Model 18T</p> <p>Differential High input limited slip differential with spiral bevel gears.</p> <p>Final Drive Outboard heavy duty planetary on all axles</p>	<p>FRONT SUSPENSION</p> <p>Semi-independent, leading A-frame supported by hydro-pneumatic suspension struts.</p> <p>REAR SUSPENSION</p> <p>Pivoting walking beams with laminated rubber suspension blocks</p> <p>HYDRAULIC SYSTEM</p> <p>Full load sensing system serving the prioritized steering, body tipping and brake functions. A ground-driven, load sensing emergency steering pump is integrated into the main system.</p> <p>Pump Type Variable displacement load sensing piston.</p> <p>Flow 165 l/min (44 gal/min)</p> <p>Pressure 28 Mpa (4 061 psi)</p> <p>Filter 5 microns</p>	<p>ELECTRICAL SYSTEM</p> <p>Voltage 24 V</p> <p>Battery Type Two AGM (Absorption Glass Mat) type</p> <p>Battery Capacity 2 X 75 Ah</p> <p>Alternator Rating 28 V 80 A</p>																					
	<p>BRAKING SYSTEM</p> <p>Service Brake Dual circuit, full hydraulic actuation dry disc brakes with 8 calipers (4F, 2M, 2R).</p> <p>Maximum brake force: 184 kN (41 400 lbf)</p> <p>Park & Emergency Spring applied, air released driveline mounted disc.</p> <p>Maximum brake force: 214 kN (48 200 lbf)</p> <p>Auxiliary Brake Automatic exhaust valve brake and engine valve brake. Automatic, adjustable, integral, hydrodynamic transmission retarder. Output shaft speed dependant.</p> <p>Total Retardation Power 266kW (357 hp) Continuous 554 kW (788 hp) Maximum</p>	<p>STEERING SYSTEM</p> <p>Double acting cylinders, with ground-driven emergency steering pump.</p> <p>Lock to lock turns 4,1</p> <p>Steering Angle 45°</p>	<p>VEHICLE SPEEDS</p> <table border="1"> <tbody> <tr> <td>1st</td> <td>7 km/h</td> <td>4 mph</td> </tr> <tr> <td>2nd</td> <td>15 km/h</td> <td>9 mph</td> </tr> <tr> <td>3rd</td> <td>23 km/h</td> <td>14 mph</td> </tr> <tr> <td>4th</td> <td>35 km/h</td> <td>22 mph</td> </tr> <tr> <td>5th</td> <td>47 km/h</td> <td>29 mph</td> </tr> <tr> <td>6th</td> <td>50 km/h</td> <td>31 mph</td> </tr> <tr> <td>R</td> <td>7 km/h</td> <td>4 mph</td> </tr> </tbody> </table>	1st	7 km/h	4 mph	2nd	15 km/h	9 mph	3rd	23 km/h	14 mph	4th	35 km/h	22 mph	5th	47 km/h	29 mph	6th	50 km/h	31 mph	R	7 km/h	4 mph
1st	7 km/h	4 mph																						
2nd	15 km/h	9 mph																						
3rd	23 km/h	14 mph																						
4th	35 km/h	22 mph																						
5th	47 km/h	29 mph																						
6th	50 km/h	31 mph																						
R	7 km/h	4 mph																						
		<p>DUMPING SYSTEM</p> <p>Two double-acting, single stage, dump cylinders</p> <p>Raise Time 14,5 s</p> <p>Lowering Time 7,5 s</p> <p>Tipping Angle 70° standard, or any lower angle programmable</p>	<p>CAB</p> <p>ROPS/FOPS certified 74 dBA internal sound level measured according to ISO 6396.</p>																					

Load Capacity & Ground Pressure

OPERATING WEIGHTS		GROUND PRESSURE				LOAD CAPACITY		OPTION WEIGHTS	
UNLADEN	kg (lb)	LADEN-No sinkage		LADEN-15% sinkage		BODY	m ³ (yd ³)		kg (lb)
Front	9 750 (21 495)	23.5R25	kPa (Psi)	23.5R25	kPa (Psi)	Struck Capacity	14 (18,3)	Bin liner	1 182 (2 606)
Middle	4 800 (10 582)					SAE 2:1 Capacity	17,5 (22,9)	Tailgate	825 (1 819)
Rear	4 760 (10 494)	Middle	378 (55)	Middle	314 (46)	SAE 1:1 Capacity	21 (27,5)	Extra wheelset	565 (1 246)
Total	19 310 (42 571)					SAE 2:1 Capacity with tailgate	18 (23,5)		
LADEN									
Front	13 120 (28 925)					Rated Payload	28 000 kg (61 729 lbs)		
Middle	17 115 (37 732)								
Rear	17 075 (37 644)								
Total	47 310 (104 301)								

Dimensions

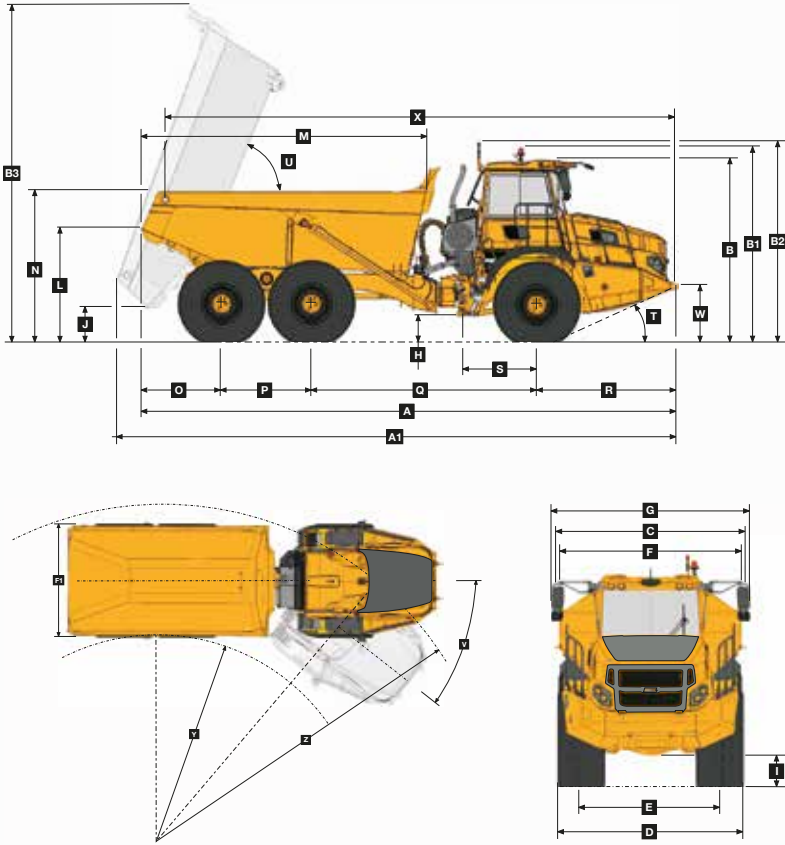

Machine Dimensions

A	Length - Transport Position	9953 mm (32 ft. 7 in.)
A1	Length - Bin Fully Tipped	10395 mm (34 ft. 1 in.)
B	Height - Transport Position	3426 mm (11 ft. 2 in.)
B1	Height - Rotating Beacon	3661 mm (12 ft.)
B2	Height - Load Light	3747 mm (12 ft. 3 in.)
B3	Bin Height - Fully Tipped	6307 mm (20 ft. 8 in.)
C	Width over Mudguards	2985 mm (9 ft. 9 in.)
D	Width over Tyres - 23.5R25	2940 mm (9 ft. 7 in.)
D1	Width over Tyres - 750/65 R25	2998 mm (9 ft. 10 in.)
E	Tyre Track Width - 23.5R25	2356 mm (7 ft. 8 in.)
E1	Tyre Track Width - 750/65 R25	2260 mm (7 ft. 4 in.)
F	Width over Bin	2968 mm (9 ft. 8 in.)
F1	Width over Tailgate	3268 mm (10 ft. 8 in.)
G	Width over Mirrors - Operating Position	3260 mm (10 ft. 8 in.)
H	Ground Clearance - Artic	537 mm (21.14 in.)
I	Ground Clearance - Front Axle	488 mm (19.21 in.)
J	Ground Clearance - Bin Fully Tipped	670 mm (26.38 in.)
K	Ground Clearance - Under Run Bar	N/A
L	Bin Lip Height - Transport Position	2176 mm (7 ft. 1 in.)
M	Bin Length	5294 mm (17 ft. 4 in.)
N	Load over Height	2864 mm (9 ft. 4 in.)
O	Rear Axle Centre to Bin Rear	1500 mm (4 ft. 11 in.)
P	Mid Axle Centre to Rear Axle Centre	1670 mm (5 ft. 5 in.)
Q	Mid Axle Centre to Front Axle Centre	4181 mm (13 ft. 8 in.)
R	Front Axle Centre to Machine Front	2602 mm (8 ft. 6 in.)
S	Front Axle Centre to Artic Centre	1362 mm (4 ft. 5 in.)
T	Approach Angle	25 °
U	Maximum Bin Tip Angle	70 °
V	Maximum Articulation Angle	45 °
W	Front Tie Down Height	1075 mm (3 ft. 6 in.)
X	Machine Lifting Centres	9443 mm (30 ft. 11 in.)
Y	Inner Turning Circle Radius - 23.5R25	4110 mm (13 ft. 5 in.)
Y1	Inner Turning Circle Radius - 750/65 R25	4081 mm (13 ft. 4 in.)
Z	Outer Turning Circle Radius - 23.5R25	8000 mm (26 ft. 2 in.)
Z1	Outer Turning Circle Radius - 750/65 R25	8029 mm (26 ft. 4 in.)

Grade Ability/Rimpull

1. Determine tractive resistance by finding intersection of vehicle mass line and grade line. NOTE: 2% typical rolling resistance is already assumed in chart and grade line.
2. From this intersection, move straight right across charts until line intersects rimpull curve.
3. Read down from this point to determine maximum speed attained at that tractive resistance.

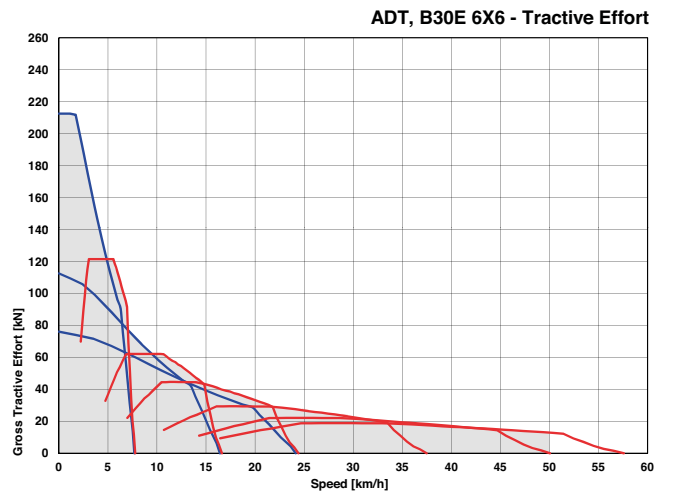
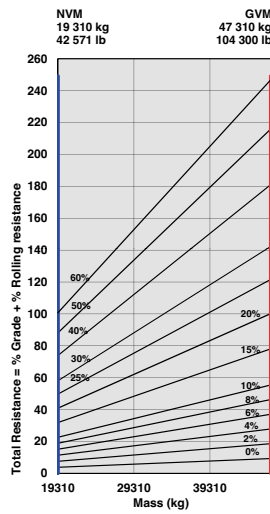

Retardation

1. Determine retardation force required by finding intersection of vehicle mass line.
2. From this intersection, move straight right across charts until line intersects the curve. NOTE: 2% typical rolling resistance is already assumed in chart.
3. Read down from this point to determine maximum speed.

