



Technical Data - B50E

ENGINE

Manufacturer
Mercedes Benz (MTU)

Model
OM473LA (MTU 6R 1500)

Configuration
Inline 6, turbocharged and intercooled.

Gross Power
430 kW (577 hp) @ 1,700 rpm

Net Power
405 kW (543 hp) @ 1,700 rpm

Gross Torque
2,750 Nm (2,028 lbf) @ 1,300 rpm

Displacement
15.6 litres (952 cu.in)

Auxiliary Brake
Engine Valve Brake

Fuel Tank Capacity
490 litres (129 US gal)

AdBlue® Tank Capacity
40 litres (11 US gal)

Certification
OM473LA (MTU 6R 1500) meets EU Stage IV / EPA Tier 4 Final emissions regulations.

TRANSMISSION

Manufacturer
Allison

Model
4800 ORS

Configuration
Fully automatic planetary transmission.

Layout
Engine mounted

Gear Layout
Constant meshing planetary gears, clutch operated

Gears
7 Forward, 1 Reverse

Clutch Type
Hydraulically operated multi-disc

Control Type
Electronic

Torque Control
Hydrodynamic with lock-up in all gears.

TRANSFER CASE

Manufacturer
Bell VGR

Model
18100

Layout
Remote mounted

Gear Layout
Three in-line helical gears

Output Differential
Interaxle 33/67 proportional differential. Automatic inter-axle differential lock.

AXLES

Manufacturer
Bell

Model
30T

Differential
High input controlled traction differential with spiral bevel gears

Final Drive
Outboard heavy duty planetary on all axles.

BRAKING SYSTEM

Service Brake
Dual circuit, full hydraulic actuation wet disc brakes on front, middle and rear axles. Wet brake oil is circulated through a filtration and cooling system.

Maximum brake force:
458 kN (102,962 lbf)

Park & Emergency
Spring applied, air released driveline mounted disc.

Maximum brake force:
215.5 kN (48,446 lbf)

Auxiliary Brake
Automatic engine valve brake. Automatic retardation through electronic activation of wet brake system.

Total Retardation Power
Continuous: 546 kW (732 hp)
Maximum: 963 kW (1,291 hp)

WHEELS

Type
Radial Earthmover

Tyre
875/65 R 29 (29.5 R 25 optional)

FRONT SUSPENSION

Semi-independent, leading A-frame supported by hydro-pneumatic suspension struts. Suspension is electronically controlled adaptive suspension with ride height adjustment.

REAR SUSPENSION

Pivoting walking beams with laminated rubber suspension blocks. Option: Comfort Ride suspension walking beams, with two-stage sandwich block.

HYDRAULIC SYSTEM

Full load sensing system serving the prioritized steering, body tipping, suspension and brake functions. A ground-driven, load sensing emergency steering pump is integrated into the main system.

Pump Type
Variable displacement load sensing piston

Flow
330 L/min (87 gal/min)

Pressure
315 bar (4,569 psi)

Filter
5 microns

STEERING SYSTEM

Double acting cylinders, with ground-driven emergency steering pump.

Lock to lock turns
4.9

Steering Angle
42°

DUMPING SYSTEM

Two double-acting, single stage, dump cylinders.

Raise Time
11.5 seconds

Lowering Time
6 seconds

Tipping Angle
70 deg standard, or any lower angle programmable

PNEUMATIC SYSTEM

Air drier with heater and integral unloader valve, serving park brake and auxiliary functions.

System Pressure
810 kPa (117 psi)

ELECTRICAL SYSTEM

Voltage
24 V

Battery Type
Two AGM (Absorption Glass Mat) type.

Battery Capacity
2 X 75 Ah

Alternator Rating
28V 80A

MAX. VEHICLE SPEED

1st	4 km/h	2.5 mph
2nd	9 km/h	6 mph
3rd	17 km/h	11 mph
4th	23 km/h	14 mph
5th	33 km/h	21 mph
6th	44 km/h	27.3 mph
7th	51 km/h	32 mph
R	7 km/h	4 mph

CAB

ROPS/FOPS certified 74 dBA internal sound level measured according to ISO 6396.

Load Capacity & Ground Pressure

OPERATING WEIGHTS		GROUND PRESSURE*		LOAD CAPACITY		OPTION WEIGHTS	
UNLADEN	kg (lb)	LADEN		BODY	m ³ (yd ³)	kg (lb)	
Front	18,484 (40,750)	(No sinkage/Total Contact Area Method)		Struck Capacity	21.5 (28)	Bin liner	1,495 (3,296)
Middle	8,648 (19,066)	875/65 R29	kPa (Psi)	SAE 2:1 Capacity	27.5 (36)	Tailgate	1,117 (2,463)
Rear	8,543 (18,834)	Front	296 (43)	SAE 1:1 Capacity	33 (43)	29.5 R 25	
Total	35,675 (78,650)	Mid & Rear	366 (53)	SAE 2:1 Capacity with Tailgate	29 (38)	(per vehicle) Minus	1,182 (2,606)
LADEN						EXTRA WHEELSET	
Front	24,204 (53,361)	29.5 R 25	kPa (Psi)			29.5 R 25	800 (1,764)
Middle	28,488 (62,805)	Front	326 (47)	Rated Payload	45,400 kg	875/65 R29	1,024 (2,258)
Rear	28,383 (62,574)	Mid & Rear	395 (57)		(100,090 lb)		
Total	81,075 (178,740)						

* 29.5R25 Groundpressures calculated with Michelin XADN+ Tyre. 875/65 R29 Groundpressures calculated with Michelin XAD65-1 Tyre.

Dimensions

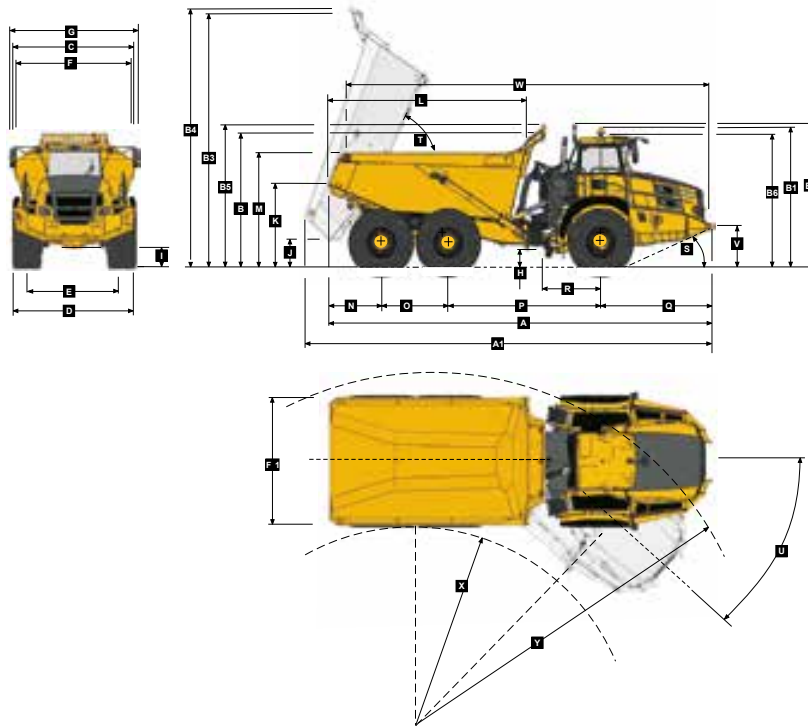

Machine Dimensions

A	Length - Transport Position with Tailgate	11272 mm (36 ft. 12 in.)
A	Length - Transport Position w/o Tailgate	11272 mm (36 ft. 12 in.)
A1	Length - Bin Fully Tipped	11916 mm (39 ft. 1 in.)
B	Height - Transport Position w/o Rock Guard	3822 mm (12 ft. 6 in.)
B	Height - Transport Position with Rock Guard	3870 mm (12 ft. 8 in.)
B1	Height - Rotating Beacon	4050 mm (13 ft. 3 in.)
B2	Height - Load Light	4141 mm (13 ft. 7 in.)
B3	Bin Height - Fully Tipped w/o Rock Guard	7325 mm (24 ft.)
B4	Bin Height - Fully Tipped with Rock Guard	7430 mm (24 ft. 5 in.)
B5	Height - Rock Guard Operating Position	4148 mm (13 ft. 7 in.)
B6	Height - Cab	3813 mm (12 ft. 6 in.)
C	Width over Mudguards	3790 mm (12 ft. 5 in.)
D	Width over Tyres - 875/65 R29	3832 mm (12 ft. 7 in.)
D	Width over Tyres - 29.5R25	3714 mm (12 ft. 2 in.)
E	Tyre Track Width - 875/65 R29	2949 mm (9 ft. 8 in.)
E	Tyre Track Width - 29.5R25	2952 mm (9 ft. 8 in.)
F	Width over Bin	3735 mm (12 ft. 3 in.)
F1	Width over Tailgate	4057 mm (13 ft. 4 in.)
G	Width over Mirrors - Operating Position	4027 mm (13 ft. 3 in.)
H	Ground Clearance - Artic	558 mm (21.97 in.)
I	Ground Clearance - Front Axle	555 mm (21.85 in.)
J	Ground Clearance - Bin Fully Tipped	907 mm (35.71 in.)
K	Bin Lip Height - Transport Position	2542 mm (8 ft. 4 in.)
L	Bin Length	5714 mm (18 ft. 9 in.)
M	Load over Height	3390 mm (11 ft. 1 in.)
N	Rear Axle Centre to Bin Rear	1533 mm (5 ft.)
O	Mid Axle Centre to Rear Axle Centre	1950 mm (6 ft. 5 in.)
P	Mid Axle Centre to Front Axle Centre	4438 mm (14 ft. 7 in.)
Q	Front Axle Centre to Machine Front	3351 mm (10 ft. 12 in.)
R	Front Axle Centre to Artic Centre	1558 mm (5 ft. 1 in.)
S	Approach Angle	23°
T	Maximum Bin Tip Angle	70°
U	Maximum Articulation Angle	42°
V	Front Tie Down Height	1269 mm (4 ft. 2 in.)
W	Machine Lifting Centres	10632 mm (34 ft. 11 in.)
X	Inner Turning Circle Radius - 875/65R29	4694 mm (15 ft. 5 in.)
X	Inner Turning Circle Radius - 29.5R25	4753 mm (15 ft. 7 in.)
Y	Outer Turning Circle Radius - 875/65R29	9408 mm (30 ft. 10 in.)
Y	Outer Turning Circle Radius - 29.5R25	9349 mm (30 ft. 8 in.)

Grade Ability/Rimpull

- Determine tractive resistance by finding intersection of vehicle mass line and grade line.
NOTE: 2% typical rolling resistance is already assumed in chart and grade line.
- From this intersection, move straight right across charts until line intersects rimpull curve.
- Read down from this point to determine maximum speed attained at that tractive resistance.

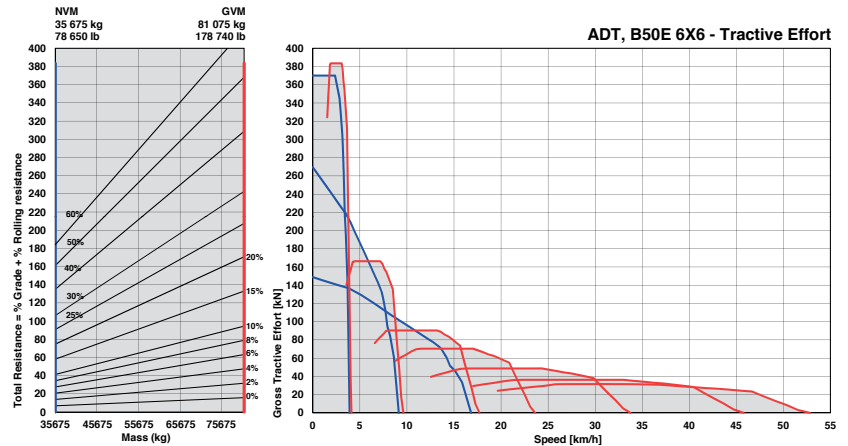

Retardation

- Determine retardation force required by finding intersection of vehicle mass line.
- From this intersection, move straight right across charts until line intersects the curve.
NOTE: 2% typical rolling resistance is already assumed in chart.
- Read down from this point to determine maximum speed.

